



Lexmark XS790 Family

Colour laser Multi-function Product



Work smart. Colour smart



Colour



10 inch
Touchscreen



Copy



Scan



Fax



Solutions



Up to
47 ppm



Duplex



Network

Why Lexmark?



Founded in 1991 from an IBM heritage in Lexington, Kentucky, Lexmark is one of the few American companies to own, develop and market monochrome laser and colour laser print technologies. Lexmark is poised to deliver on its promise to produce quality, dependable products well into the future.

Make a lasting impression with award-winning colour

The documents that you print define an important image – yours. That’s why Lexmark colour MFPs help businesses be more productive and stand out with vibrant colour. With the ability to print professional-quality colour in-house, you can add instant impact and save costs by virtually eliminating the need to outsource print jobs. Lexmark also offers a host of colour-access and control tools to manage costs.

Eco-responsible

Printing responsibly means everyone wins – your business, your budget and the environment. Lexmark’s award-winning products are designed for ease of use, high-quality output and reliable performance, with innovative capabilities that help you minimise the

number of cartridges that you use over the life of the printer and conserve paper and energy. Our goal is to design, package and deliver innovative products and solutions in an environmentally-responsible manner.

The Lexmark Cartridge Collection Programme is active around the world, providing a variety of methods for free returns of your empty cartridges to Lexmark or our collection partners. Our goal: Make it easy to do the right thing.

Environmental protection is a shared responsibility

Through work with industry groups, Lexmark helps guide the formation of standards and guiding principles for environmental sustainability.

Our memberships include:

- AeA Europe
- American National Standards Institute (ANSI)
- Ecma International
- Electronics Industry Citizenship Coalition (EICC)
- European Information & Communications Technology Industry Association (EICTA)
- Information Technology Industry Council (ITI)
- ITI Environmental Leadership Council

Overview



Robust colour output

Designed for busy colour environments, the Lexmark XS790 Family delivers vibrant, professional quality output that is consistent from the first page to the last.

- Lexmark Extra High Yield Print Cartridges are available, offering yields of up to 20,000¹ pages in black and 18,000¹ pages in colour
- Print speeds as fast as 47 ppm in both black and colour
- PANTONE® calibration for consistent colour tones
- Named Colour Replacement for easy colour matching
- Lexmark ColourCare Technology to manage colour usage and control costs
- Instant warm-up fuser to help reduce energy consumption and improve time to first page

Business productivity

The Lexmark XS790 Family combines exceptional multi-function performance with time-saving applications designed to make you more productive. These MFPs can deliver the performance of much larger copiers, but with a smaller footprint and a more affordable price.

- Duplex scanning to scan both sides of your documents in one pass

- Advanced copy functions let you interrupt long print runs to make a quick copy and proof the first copy set before completing your copy job
- Scan to multiple destinations, including scan to email, scan to FTP, scan to fax, scan to network and more
- Preloaded applications to drive greater efficiency, and Lexmark Embedded Solutions Framework to further extend the capabilities of the device

Easy and intuitive

The Lexmark XS790 Family is designed for easy operation and maintenance.

- Extra large, easy to navigate 10 inch colour touchscreen provides audible and tactile feedback to make completing tasks intuitive
- Print and scan preview features help you select documents or specific pages within a document
- Directional lights on the device provide visual cues to guide you through tasks
- Eco-friendly settings such as the Sleep Button and Hibernate Mode
- Available device fleet management software

Solutions



Save time and money through solutions

Reduce unnecessary printing and simplify work processes through Lexmark solutions. The Lexmark XS790 Family features the Lexmark Embedded Solutions Framework (eSF), our platform that enables you to add a wide range of software applications directly onto the device. Solutions are designed with your productivity in mind, helping you streamline – or even eliminate – paper intensive business processes.

The right touch

The Lexmark e-Task colour touchscreen is a key access point to your device. The extra large, customisable, 10 inch interface gives you the ability to preview thumbnails of documents prior to printing, as well as change print jobs at the device. You can even view, select and print specific pages within a document directly from the touchscreen. Its easy-to-use, intuitive navigation provides fast access to the functions and shortcuts.

The following Lexmark solutions are just a few of those available through your authorised Lexmark Business Solutions Dealers



Downtime Reports

Access critical forms and reports, even if your IT system fails or the network goes down. During any period of downtime, simply tap the touch screen, choose a folder and select the documents you need to print.



Card Copy

Same time and effort in copying identification cards, licences and insurance cards by automatically scanning, enlarging and copying both side of a two-sided card onto one side of a sheet of paper.



Scan-to-Network – Premium

Preview, enhance and index images of scanned hard copies, then route them to a shared network folder. Create high-quality images and confirm their delivery directly from the Lexmark MFP device.

The following are solutions that come preloaded on the XS790 Family MFPs



Forms and Favourites

Eliminate waste and inefficiencies associated with pre-printed forms. Store frequently printed forms, marketing materials or other documents online, then print them on demand.



Scan to Network Basic

Scan a hard copy document and route the image to one of 30 pre-defined or public shared network folders.

Vertical Solutions



Professional quality output is only part of the story

By leveraging our industry expertise, you can generate efficiency and increase productivity across business processes to gain the power that you need to move ahead. Lexmark technology solutions are tailored to your business environment – where business interactions and decisions are happening.

Empower your employees with workflow solutions that refine work processes, capture critical data and deliver information to the right place, at the right time, and in the right format. Contact your Lexmark Business Solutions Dealer for specific vertical solutions*. Solutions are customised through your dealer.



Lexmark's standard security features for your network, data and devices

Output security has never been more important to businesses of all sizes. Lexmark's security functions include device management, device hardening and device operation. Strong multi-layered security is built-in.

Device management. Tools include administrative access and passwords, HTTPS, SNMPv3, IP security (IPSec) and 802.1x support to remotely and manage device usage remotely

Device hardening. Includes port filtering, TCP connection filtering, hard drive encryption, hard disk wiping and digitally signed firmware updates that enhance the security of the device's network interface

Device operation. Utilises user authentication, address book lookup via LDAP over SSL and device lockout for protection of user information

Lexmark has shown its strength and leadership with respect to security.

- Forming and chairing the group that created the IEEE 2600 standards for security on hard copy devices
- Becoming the first hard copy device manufacturer to take a holistic approach with the National Information Assurance Partnership (NIAP) Common Criteria evaluation

Key Features



**Model shown: XS798dte
with optional finisher**



1. 10 inch colour touchscreen

Operate your device with ease through smart and intuitive navigation with audible and tactile feedback when you use the touchscreen.



2. Flexible output options

Choose from four output options, including a five-bin mailbox, an offset stacker, a staple finisher and a staple with hole punch finisher.



3. Single-pass automatic document feeder

Save time by scanning both sides of your document in one pass with robust colour-scanning capabilities and an input capacity of up to 75 pages.



4. Direct USB

The front USB port allows for convenient walk-up preview, printing and scanning and is compatible with most printable image file formats.



5. Lexmark solutions

Reduce unnecessary printing and simplify work processes through solutions applications preloaded on your device. Choose additional Lexmark solutions to fit your unique workflow needs.



6. Long-lasting toner

The Lexmark Extra High Yield Print Cartridge delivers up to 20,000¹ pages in black and 18,000¹ pages in colour, reducing interventions, cartridge waste and cost.

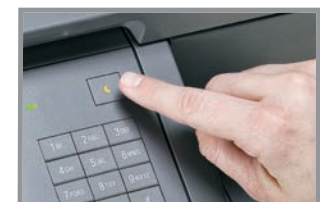

7. Eco-friendly features

Easy-to-access features like Eco-Mode to reduce paper and toner consumption, the Sleep Button and Hibernate Mode make it easy to print responsibly and help you save energy.

Lexmark XS790 Family Ordering Information

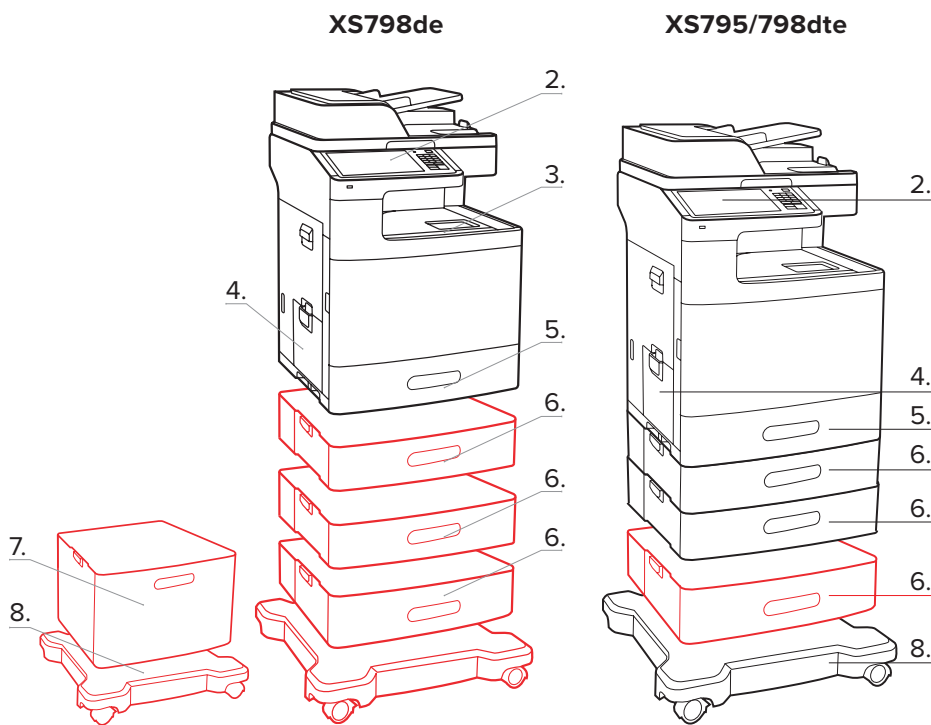

* Caster base required

1. Finishing Functions

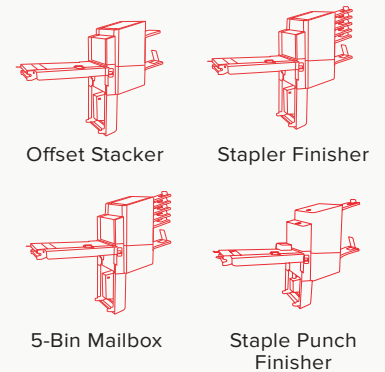

2. 25.9 cm Touchscreen
3. 500-Sheet Output Bin
4. 100-Sheet Multi-purpose Feeder
5. 500-Sheet Tray
6. 500-Sheet Drawer
7. 2,000-Sheet High-Capacity Feeder*
8. Caster Base

■ Standard
■ Optional

Compatible on the XS790 family

Part No.	Model
3081157	Lexmark XS795dte
3081158	Lexmark XS798dte
3081160	Lexmark XS798de

Part No.	Laser Toner/Print Cartridge
24B6022	XS795, XS798 Black Extra High Yield Return Programme Print Cartridge
24B6018	XS795, XS798 Cyan Extra High Yield Return Programme Print Cartridge
24B6019	XS795, XS798 Magenta Extra High Yield Return Programme Print Cartridge
24B6021	XS795, XS798 Yellow Extra High Yield Return Programme Print Cartridge
C792X77G	C792, X792 Waste Toner Bottle
25A0013	Staple Cartridges (3 pack)

Part No.	Paper Handling
47B0110	C792, X792 550-Sheet Drawer
47B1101	C792, X792 5-Bin Mailbox
47B1102	C792, X792 500-Sheet Offset Stacker
47B1100	C792, X792 500-Sheet Staple Finisher
47B1103	C792, X792 500-Sheet Staple, Hole Punch Finisher
47B0112	C792, X792 Spacer
47B0118	X792 Banner Media Tray
47B0111	2,000-sheet High Capacity Feeder

Part No.	Memory Options
1025041	256MB DDR2-DRAM
1025042	512MB DDR2-DRAM
1025043	1024MB DDR2-DRAM

Part No.	Memory Options
14F0245	256MB Flash Card
30G0287	Arabic Font Card
30G0828	Japanese Font Card
30G0825	Korean Font Card
30G0826	Simplified Chinese Font Card
30G0827	Traditional Chinese Font Card

Part No.	Application Solutions
47B1111	X792 Card for IPDS
47B1110	X792 Forms and Bar Code Card
47B1112	X792 Card for PRESCRIBE Emulation
57X9000	Lexmark PrintCryption Card

Part No.	Connectivity
27X0025	MarkNet N8250 802.11b/g/n Wireless Print Server
14F0042	MarkNet N8130 Fiber Ethernet 100BaseFX, 10BaseFL Print Server
14T0220	MarkNet™ N7020e Gigabit Ethernet Print Server
1021294	USB Cable (2-metre)
14F0000	Parallel 1284-B Interface Card
1021231	Parallel Cable (10-foot)
14F0100	RS-232C Serial Interface Card

Lexmark XS790 Family Product Specifications



Product specifications	Lexmark XS795dte	Lexmark XS798de	Lexmark XS798dte
Printing			
Display	Lexmark e-Task 10.2-inch (25.9 cm) Colour touchscreen with audible and tactile feedback		
Print Speed: Up to	Black: 35 ppm / Colour: 35 ppm	Black: 47 ppm / Colour: 47 ppm	Black: 47 ppm / Colour: 47 ppm
Time to First Page: As fast as	Black: 9 seconds / Colour: 10 seconds	Black: 8 seconds / Colour: 8.5 seconds	Black: 8 seconds / Colour: 8.5 seconds
Print Resolution, Colour	1200 x 1200 dpi, 4800 Colour Quality (2400 x 600 dpi)		
Processor Speed	1.2 GHz		
Memory	Standard: 1024 MB / Maximum: 2048 MB	Standard: 2048 MB / Maximum: 2048 MB	Standard: 2048 MB / Maximum: 2048 MB
Hard Disk	Included in configuration		
Recommended Monthly Page Volume ²	2,500 - 14,000 pages	2,500 - 17,000 pages	2,500 - 17,000 pages
Maximum Monthly Duty Cycle: Up to ³	150,000 pages per month		
Copying			
Copy Speed: Up to	Black: 35 ppm / Colour: 35 ppm	Black: 47 ppm / Colour: 47 ppm	Black: 47 ppm / Colour: 47 ppm
Time to First Copy: As fast as	Black: 11.5 seconds / Colour: 13.5 seconds	Black: 10 seconds / Colour: 11 seconds	Black: 10 seconds / Colour: 11 seconds
Reduce / Enlarge Range	25 - 400%		
Scanning			
Duplex Scan Speed: Up to	A4/Ltr, Black: 56 / 58 sides per minute – A4/Ltr, Colour: 52 / 54 sides per minute		
Simplex Scan Speed: Up to	A4/Ltr, Black: 47 / 49 sides per minute – A4/Ltr, Colour: 47 / 49 sides per minute		
Scanner Type	Flatbed scanner with ADF		
Hardware Scanning Resolution	600 X 600 ppi		
Faxing			
Modem Speed	33.6 Kbps		
Supplies			
Supplies Yield	18,000 ¹ -page Colour Extra High Yield Print Cartridges (CMY), 20,000 ¹ -page Black Extra High Yield Print Cartridge		
Supplies Delivered with the Product	12,000 ⁴ -page Black and Colour (CMY) Starter Return Programme Print Cartridges		
Paper Handling			
Paper Handling Standard	500-Sheet Output Bin, Integrated Duplex, 100-Sheet Multi-purpose Feeder, 550-Sheet Input Tray, 2 x 550-Sheet Drawers	500-Sheet Output Bin, Integrated Duplex, 100-Sheet Multi-purpose Feeder, 550-Sheet Input Tray	500-Sheet Output Bin, Integrated Duplex, 100-Sheet Multi-purpose Feeder, 550-Sheet Input Tray, 2 x 550-Sheet Drawers
Paper Handling Optional	5-Bin Mailbox, 550-Sheet Drawer, Banner Media Tray, 500-Sheet Offset Stacker, 500-Sheet Staple Finisher, 500-Sheet Staple Punch Finisher	5-Bin Mailbox, 550-Sheet Drawer, 500-Sheet Offset Stacker, 500-Sheet Staple Finisher, 500-Sheet Staple Punch Finisher, 2,000-Sheet High Capacity Feeder	5-Bin Mailbox, 550-Sheet Drawer, Banner Media Tray, 500-Sheet Offset Stacker, 500-Sheet Staple Finisher, 500-Sheet Staple Punch Finisher
Paper Input Capacity: Up to	Standard: 1,750 pages 20 lb or 75 gsm bond / Maximum: 3,200 pages 20 lb or 75 gsm bond (Remove 550-Sheet Drawer, add 2,000-Sheet High Capacity Feeder)	Standard: 650 pages 75 gsm bond / Maximum: 2,650 pages 75 gsm bond	Standard: 1,750 pages 20 lb or 75 gsm bond / Maximum: 3,200 pages 20 lb or 75 gsm bond (Remove 550-Sheet Drawer, add 2,000-Sheet High Capacity Feeder)
Paper Output Capacity: Up to	Standard: 500 pages 20 lb or 75 gsm bond / Maximum: 1,000 pages 20 lb or 75 gsm bond	Standard: 500 pages 75 gsm bond / Maximum: 1,000 pages 75 gsm bond	Standard: 500 pages 20 lb or 75 gsm bond / Maximum: 1,000 pages 20 lb or 75 gsm bond
Media Types Supported	Card Stock, Dual Web Labels, Envelopes, Glossy Paper, Integrated Labels, Paper Labels, Plain Paper, Polyester Labels, Transparencies, Vinyl Labels, Refer to the Card Stock & Label Guide, Outdoor Media, Banner Paper		
Media Sizes Supported	10 Envelope, 7 3/4 Envelope, 9 Envelope, A4, A5, B5 Envelope, C5 Envelope, DL Envelope, Executive, Folio, JIS-B5, Legal, Letter, Statement, Universal		
General			
Standard Ports	USB 2.0 Specification Hi-Speed Certified (Type B), Front USB 2.0 Specification Hi-Speed Certified Port (Type A), Rear USB 2.0 Specification Hi-Speed Certified Port (Type A), Ethernet 10/100/1000 BaseTX (RJ-45)		
Optional Network Ports	External MarkNet™ N7020e Gigabit Ethernet, Internal MarkNet™ N8130 Fiber Fast Ethernet, Internal MarkNet™ N8250 802.11b/g/n Wireless		
Optional Local Ports	Internal RS-232C serial, Internal 1284-B Bi-directional Parallel		
Noise Level, Operating	Printing: 51 dBA / Copy: 52 dBA / Scan: 54 dBA	Printing: 53 dBA / Copy: 53 dBA / Scan: 54 dBA	Printing: 52 dBA / Copy: 53 dBA / Scan: 54 dBA
Energy Star	Yes		
Specified Operating Environment	Temperature: 16 to 32°C (60 to 90°F), Humidity: 8 to 80% Relative Humidity, Altitude: 0 - 3,048 Metres (10,000 Feet)		
Size (in. - H x W x D) / Weight (lb.)	47.4 x 24.05 x 25.9 in. / 247 lb.		

¹Based on approximately 5% print coverage. Actual yields may vary based on factors such as page coverage, image type, job size, print/copy/fax modes and duplexing.

²Recommended Monthly Page Volume is a range of pages that helps customers evaluate Lexmark's product offerings based on the average number of pages customers plan to print on the device each month. Lexmark recommends that the number of pages per month be within the stated range for optimum device performance, based on factors including: supplies replacement intervals, paper loading intervals, speed and typical customer usage.

³Maximum Monthly Duty Cycle is defined as the maximum number of pages a device could deliver in a month using a multi-shift operation. This metric provides a comparison of robustness in relation to other Lexmark printers and MFPs.

⁴Average continuous black or continuous composite CMY declared cartridge yield in one-sided (simplex) mode up to this number of standard pages in accordance with ISO/IEC 19798.



Lexmark and Lexmark with the diamond design are trademarks of Lexmark International, Inc., registered in the United States and/or other countries. All other trademarks are the property of their respective owners. ENERGY STAR® is a US registered mark. Information in this document is subject to change without notice. Unison is a trademark of Lexmark International, Inc. Information in this document is subject to change without notice.

AirPrint and the AirPrint logo are trademarks of Apple Inc.