













Lexmark XS748de Colour laser MFP



Intuitive colour MFP for busy workgroups

-  Colour
-  17.8-cm (7-Inch) Touch Screen
-  Copy
-  Scan
-  Fax
-  Solutions
-  Up to 33 ppm
-  Duplex
-  Network
-  Eco-Mode
-  Security
-  Flexible Input

LEXMARK
TM

Why Lexmark?

Founded in 1991 from an IBM heritage in Lexington, Kentucky, Lexmark is one of the few American companies to own, develop and market inkjet, monochrome laser and colour laser print technologies. Lexmark is poised to deliver on its promise to produce quality, dependable products well into the future.

Lexmark XS748de Overview



Robust high-quality colour Rely on the Lexmark XS748de colour laser MFP for the high-quality colour printing, scanning and copying essential to business.

- Match corporate colours with Lexmark Named Color Replacement and PANTONE® calibration.
- Lexmark high-yield cartridges let you print up to 12,000 pages per cartridge in black and 10,000 pages per cartridge in colour.¹
- Print and copy quickly at speeds up to 33 ppm and a time to first page as fast as 9 seconds in both black and colour.
- The high-speed processor, 512MB RAM and Gigabit Ethernet networking mean fast data transfer and fast processing, even on complex colour documents.
- Reliable paper feeding supports diverse media, including card stock, vinyl labels, banners and more.



Performance and productivity The combination of easy-to-use features and reliable performance means business processes are intuitive and you are productive.

- The easy-to-use 7-inch (17.8-cm) colour touch screen provides audible feedback and tablet-like navigation.
- Expand input capacity with optional paper drawers that boost total input capacity up to 4,300 sheets.
- Quickly print and copy documents using the instant warm-up fuser that also reduces energy consumption.
- Create custom messages to provide helpful information such as helpdesk telephone numbers and company communications.
- Instead of installing individual drivers for each printer model, the Lexmark Universal Print Driver provides a standardised, one-driver solution.



Business solutions The Lexmark Embedded Solutions Framework (eSF) helps expand functionality, move information more efficiently, lower costs and analyse usage patterns.

- Quickly and efficiently access basic eSF solutions directly from the 7-inch (17.8-cm) colour touch screen.
- The hard disk supplied as a standard provides the ability to store files on the device and run additional solutions with ease.
- Pre-loaded solutions mean you can be productive and save time, money and paper right out of the box.
- Additional solutions are available for greater savings and productivity.
- Models with solutions capabilities also have the card reader option for greater security.

¹ Average continuous black or composite CMY declared cartridge yield in accordance with ISO/IEC 19798.



Why Lexmark colour?

The documents you print define an important image – yours. The Lexmark XS748de colour laser MFP is perfect for printing reports, marketing collateral and on-demand signage with brilliant colour reproduction. So when you put a high-quality colour document in a client's hands, you're advancing communication and your company's image at the same time.

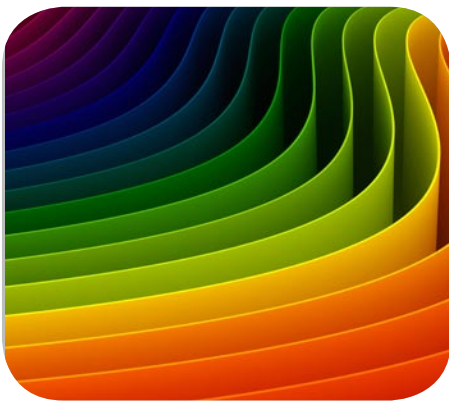

Professional colour quality Colour communicates, informs and persuades. Vibrant, expressive colour also attracts attention and increases impact. In short, colour is your brand – who you are. The Lexmark XS748de colour laser MFP is a colour powerhouse. It offers repeatable, accurate colour matching and features that create continuity from one document to the next.

- **Easy brand matching** - Match corporate colours on marketing collateral and logos with Lexmark Named Color Replacement. Simply enter specific colour values for easy colour matching, including company defined colours and PANTONE® colour.
- **Money saving colour** - Colour is business critical, but often it is seen as expensive or wasteful. Lexmark ColorCare Technology helps change that perception. Tools, like User Quotas, help you manage and make intelligent decisions about colour printing.
- **Continuous colour** - Print with confidence, knowing the Lexmark XS748de MFP produces documents at optimum quality. Status screens and supply alerts notify you when toner is low, so you don't run out in the middle of a job.



Professional colour performance Whether you need one document or many, consistency is important. The Lexmark XS748de colour laser MFP delivers in all types of situations – last minute presentations, large print jobs for promotional events or constantly used forms. It creates high-quality documents on a variety of media while helping you save money at the same time.

- **Consistent colour across media** - Lexmark colour technology gives you consistent, professional colour on a variety of media types and sizes. Carry a consistent look across materials and show clients your true colours, no matter what you provide to them.
- **Print on demand** - Eliminate waste. Don't print forms, marketing materials or other documents externally and store the paper versions. Instead, with the Forms and Favourites solution, store frequently required files online and print in-house and on demand.
- **On-the-fly updates** - Create custom colour documents directly from the Lexmark XS748de MFP. Use print preview and post process job changes to make updates like removing a cover page or switching between simplex and duplex printing.

Lexmark XS748de Solutions

Reduce unnecessary printing and simplify work processes through Lexmark solutions. The Lexmark Embedded Solutions Framework (eSF) enables you to add a wide range of software apps directly onto the device. Solutions are designed with your productivity in mind, helping you streamline—or even eliminate—paper intensive business processes.

Lexmark XS748de Built-in solutions

The following apps are available on the Lexmark XS748de colour laser MFP.



Forms and Favorites

Eliminate waste and inefficiencies associated with preprinted forms. Rather than printing collateral externally and storing the paper versions, store frequently required files online. Then print them in-house and on demand.



Scan to Network

Lets you capture a digital image of a hardcopy document and route the file to a shared network folder. You can preview the first page, rescan the document if necessary, and print a confirmation page with delivery status and time.



Change Background

Communicate to customers and employees and make the device truly your own. Customise the background or a timed idle screen to show one of the four preloaded backgrounds or any image you want, such as a photo or logo.



Change Language

Easily switch the language displayed on the touch screen – 18 languages are supported.



Lexmark XS748de Additional solutions

In addition to the solutions built into the device, a diverse portfolio of additional Lexmark solutions is available to help accommodate your workflow needs. The following are just a few examples.



Customer Support

Lets you send an e-mail alert to your help desk or service provider to request service or support. Pertinent information about the device can be automatically attached to the e-mail message.



Google Cloud Print

With the Lexmark Google Cloud Print™ app, you can print from Gmail and Google Docs from your smart phone or tablet. Your documents remain in the Google Cloud until you log into your Google account using the touch screen on your Lexmark printer.



Device Quotas

Allows the Administrator to configure user level quotas for Print, Scan, Copy, and Outbound Fax on devices with the optional hard disk.

Contact your Lexmark Business Solutions Dealer for additional solutions.

Lexmark XS748de Key features

Features that help you optimise your work



Lexmark XS748de colour laser MFP shown with optional 2,000-sheet high capacity feeder and caster base.



1) Easy brand matching
Consistently match branded colours and print marketing collateral in-house with Lexmark Named Color Replacement.



2) Intuitive colour touch screen
Operate your printer with ease and confidence using the 7-inch (17.8-cm) colour touch screen that makes navigation smart and intuitive.



3) Convenient updates
Preview documents and change output settings, such as two-sided printing, directly at the device.



4) Flexible input capacity
With optional 550-sheet drawers, a specialty media drawer and a 2,000-sheet high capacity feeder, customise input options to meet your printing needs.



5) Two-sided printing
Reduce paper consumption by up to 50% and reduce your impact on the environment with two-sided printing.



6) Walk-up USB printing
The front USB port allows for convenient walk-up preview, printing and scanning of PDFs and many printable image file formats.



7) Eco-friendly printing
Print responsibly with Eco-Settings that let you customise print settings and Hibernate Mode which reduces energy consumption to less than one watt.



8) Built-in security
Advanced security controls protect data at every stage: from user authentication to security audits and disk wiping.

Lexmark XS748de Ordering information

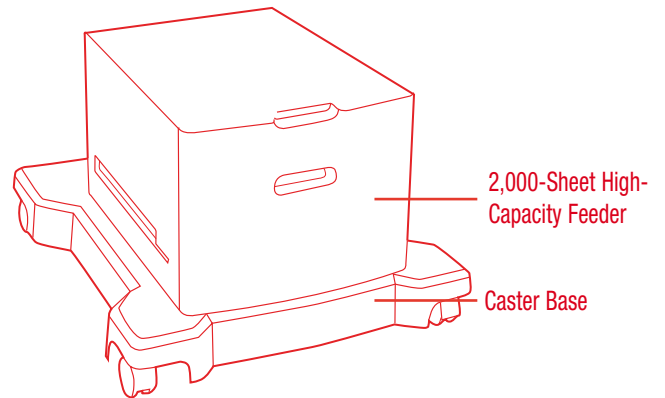
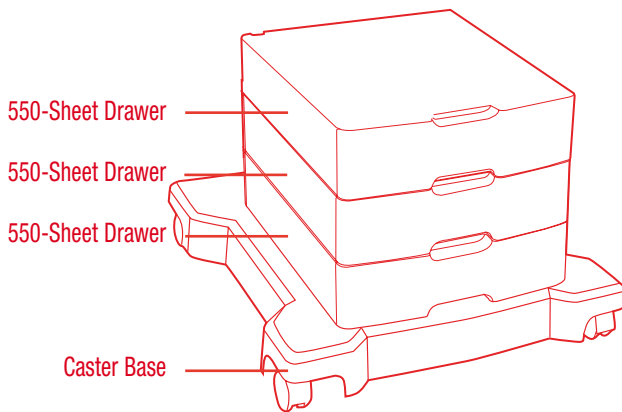
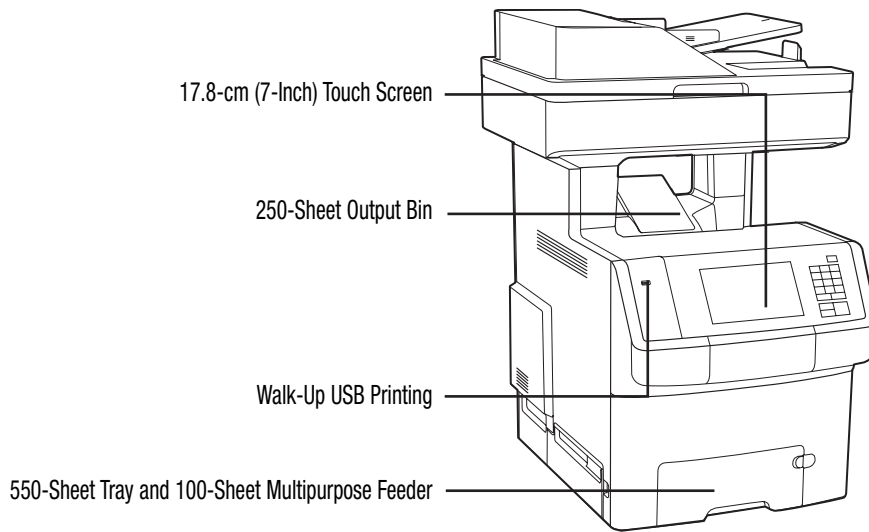

- Standard
- Optional

Compatible with Lexmark XS748de MFP

Part #	Model	1025042	512MB DDR2-DRAM	40X5187	ADF Separator Pad
34T5142	Lexmark XS748de	1025043	1024MB DDR2-DRAM	40X5188	ADF Pick Assembly
Part #	Laser Toner/Print Cartridge	14F0245	256MB Flash Card	40X5189	ADF Pick Pad
24B5700	XS748 Black High Yield Return Program Toner Cartridge	30G0287	Arabic Font Card	40X5168	Pick Tire
24B5701	XS748 Cyan High Yield Return Program Toner Cartridge	30G0828	Japanese Font Card	40X5152	Pick Tire, Specialty Media Drawer
24B5702	XS748 Magenta High Yield Return Program Toner Cartridge	30G0825	Korean Font Card	40X6401	Transfer Belt Maintenance Kit
24B5703	XS748 Yellow High Yield Return Program Toner Cartridge	30G0826	S.Chinese Font Card		
C734X20G	Photoconductor Unit, 4-Pack (20K)	30G0827	T.Chinese Font Card		
C734X24G	Photoconductor Unit, 4-Pack (20K each)	Part #	Application Solutions		
C734X77G	Waste Toner Box (25K)	57X9000	Lexmark PrintCrypton Card		
Part #	Paper Handling	34T5121	X746, X748 Card for IPDS		
27S2100	550-Sheet Drawer	34T5122	X746, X748 Card for PRESCRIBE Emulation		
27S2400	2000-Sheet High Capacity Feeder	34T5120	X746, X748 Forms and Bar Code Card		
27S2650	550-Sheet Specialty Media Drawer	Part #	Connectivity		
27S2190	4.8 inch (12.2 cm) Spacer	27X0030	MarkNet N8250 802.11b/g/n Wireless Print Server		
Part #	Furniture	14F0037	MarkNet N8120 Gigabit Ethernet Print Server		
30S2765	Swivel Cabinet	1021294	USB (2 Meter) Cable		
34T5114	C74x, X74x Caster Base	14F0000	Parallel 1284-B Interface Card		
16C0379	T Low Profile Printer Stand	1021231	Parallel (10') Cable		
Part #	Memory Options	14F0100	RS-232C Serial Interface Card		
1025041	256MB DDR2-DRAM	Part #	User Replaceable Parts		
		40X8111	C74x, X74x Fuser Maintenance 220-240V		

Lexmark XS748de Product specifications



Product specifications

Lexmark XS748de

Printing	
Display	Lexmark e-Task 17.8 cm (7-inch) colour touch screen
Print Speed: Up to	Black: 33 ppm / Colour: 33 ppm
Time to First Page: As fast as	Black: 9 seconds / Colour: 9 seconds
Print Resolution, Colour	1200 x 1200 dpi, 4800 Colour Quality (2400 x 600 dpi)
Processor Speed	1.2 GHz
Memory	Standard: 512 MB / Maximum: 1536 MB
Hard Disk	Included in configuration
Recommended Monthly Page Volume ²	3000 - 10000 pages
Maximum Monthly Duty Cycle: Up to ³	100000 pages per month
Copying	
Copy Speed: Up to	Black: 33 cpm / Colour: 33 cpm
Time to First Copy: As fast as	Black: 13 seconds / Colour: 13.5 seconds
Reduce / Enlarge Range	25 - 400%
Scanning	
Duplex Scan Speed: Up to	A4/Ltr, Black: 12 / 12 sides per minute - A4/Ltr, Colour: 12 / 12 sides per minute
Simplex Scan Speed: Up to	A4/Ltr, Black: 34 / 35 sides per minute - A4/Ltr, Colour: 33 / 35 sides per minute
Scanner Type	Flatbed scanner with ADF
Optical Scanning Resolution	600 X 600 ppi
Faxing	
Modem Speed	33.6 Kbps
Fax Transmission Speed	< 3 seconds per page
Supplies	
Supplies Yield	12,000 ¹ -page Black High Yield Toner Cartridge, 10,000 ¹ -page Colour High Yield Toner Cartridges (CMY)
Cartridge(s) Shipping with Product	12,000 ¹ -page Black High Yield Return Program Toner Cartridge, 10,000 ¹ -page Colour (CMY) High Yield Return Program Toner Cartridges
Paper Handling	
Paper Handling Standard	550-Sheet Input Tray, 250-Sheet Output Bin, Integrated Duplex, 100-Sheet Multipurpose Feeder
Paper Handling Optional	550-Sheet Specialty Media Drawer, 550-Sheet Drawer, 2,000-Sheet High Capacity Feeder
Paper Input Capacity: Up to	Standard: 650 pages 75 gsm bond / Maximum: 4300 pages 75 gsm bond
Paper Output Capacity: Up to	Standard: 250 pages 75 gsm bond / Maximum: 250 pages 75 gsm bond
Media Types Supported	Refer to the Card Stock & Label Guide, Vinyl Labels, Transparencies, Card Stock, Paper Labels, Envelopes, Plain Paper
Media Sizes Supported	A6, 10 Envelope, Universal, Statement, Letter, Legal, JIS-B5, Folio, Executive, B5, DL Envelope, C5 Envelope, B5 Envelope, A5, A4, 9 Envelope, 7 3/4 Envelope, Oficio
General	
Connectivity (standard)	Ethernet 10/100/1000 BaseTX (RJ-45), Rear USB 2.0 Specification Hi-Speed Certified port (Type A), Front USB 2.0 Specification Hi-Speed Certified port (Type A), USB 2.0 Specification Hi-Speed Certified (Type B)
Connectivity (optional)	Internal MarkNet™ N8250 802.11b/g/n Wireless, Internal MarkNet™ N8120 Gigabit Ethernet
Other Attachment Options	Parallel 1284-B Interface Card, RS-232C Serial Interface Card
Noise Level, Operating	Print: 57 dBA / Copy: 58 dBA / Scan: 54 dBA
ENERGY STAR	Yes
Specified Operating Environment	Humidity: 8 to 80% Relative Humidity, Temperature: 16 to 32°C (60 to 90°F), Altitude: 0 - 3048 Meters (10,000 Feet)
Size (mm. - H x W x D) / Weight (kg)	787 x 546 x 622 mm / 44.2 kg

¹ Average continuous black or composite CMY declared cartridge yield in accordance with ISO/IEC 19798.

² "Maximum Monthly Duty Cycle" is defined as the maximum number of pages a device could deliver in a month using a multisheet operation. This metric provides a comparison of robustness in relation to other Lexmark printers and MFPs.

³ "Recommended Monthly Page Volume" is a range of pages that helps customers evaluate Lexmark's product offerings based on the average number of pages customers plan to print on the device each month. Lexmark recommends that the number of pages per month be within the stated range for optimum device performance, based on factors including: supplies replacement intervals, paper loading intervals, speed, and typical customer usage.